

EMIT

TECHNICAL BULLETIN TB-6592 50571 CHARGED PLATE ANALYZER



Table of Contents

Safety	iii
Safety Precautions for the EMIT 50571	v
Preface	vii

Section I Introduction

General Information	I-1
Modes of Operation	I-2
Incoming Inspection	I-3
Incoming Confidence Test	I-4

Section II Installation

Mounting	II-1
Battery Operation	II-2
Battery Charger/Eliminator Connection	II-3
Initial Setup Connections	II-4

Section III Operation

Front Panel Features	III-1
Rear Panel Features	III-3
Float Mode Operation	III-4
Decay Mode Operation	III-4
Programming Operation	III-5
Programming the START voltage	III-5
Programming the STOP voltage	III-6
Monitoring the Plate Voltage using the Output Monitor	III-7

Table of Contents

Section IV Specifications

Specifications IV-1

Section V Maintenance

Safety Precautions for the EMIT 50571 V-1
Battery Pack Maintenance V-1
Preventative Maintenance V-2
Customer Service Assistance V-2
Service Information. V-3

Appendixes

- Appendix A* Warranty Statement
- Appendix B* Sales and Service

Safety

Review the following safety precautions to maintain safety and prevent damage to the instrument or equipment connected to it.

The safety features of this instrument may be ineffective if the equipment is not operated in the manner stated in this manual.

Refer all maintenance procedures to qualified personnel.

Safety Precautions

Power

Observe polarity of connections and use appropriate battery eliminator ratings for voltage and current.

Avoid Electric Overload

To avoid electric shock or fire hazard, do not apply a voltage to a terminal that is outside the range specified for that terminal.

Avoid Electric Shock

To avoid electric shock, do not touch the charged-plate while the instrument is on.

Do Not Operate Without Covers

To avoid electric shock or fire hazard, do not operate this instrument with the covers removed.

Fuses

There are no user serviceable fuses inside this unit. Please refer all problems to EMIT Customer Service.

Safety Precautions (cont.)

Indoor Use Only

This instrument is intended for indoor use only.

Do Not Operate in Wet or Damp Conditions

To avoid electric shock, do not operate this instrument in wet or damp conditions.

Do Not Operate in an Explosive Environment

To avoid injury or fire hazard, do not operate this instrument in an explosive environment.

Product Protection Precautions

Use the Proper Power Source

Do not operate this instrument from a power source that is different than the voltage specified on the serial number tag.

Provide Proper Ventilation

To prevent the instrument from overheating, provide proper ventilation.

Do Not Operate with Suspected Failures

If you suspect there is damage to this instrument, have it inspected by qualified personnel.

Safety Terms and Symbols

Terms in the Manual

These terms may appear in this manual:

Warning: Warning statements identify conditions or practices that could result in injury or loss of life.

Caution: Caution statements identify conditions or practices that could result in damage to this product or other equipment.

Symbols on the Product

These symbols may appear on the instrument:



Warning, risk of electric shock



Caution, refer to Operator's Manual

CAT I

Installation category I (overvoltage category): Classification for the operation of a unit using voltage systems or circuits with required standardized limits for transient voltages. Category I pertains to voltages supplied at the peripheral level, with smaller tolerances for transient voltages as specified by the Low-Voltage Safety standard (EN 61010-1).



This symbol refers to the compliance of the equipment to the European Council (E.C.) standards.

Safety Precautions for the EMIT 50571

Please observe the following safety precautions when checking connections or providing maintenance procedures on the EMIT 50571:

1. Refer all maintenance procedures to qualified personnel.
2. Prior to performing maintenance procedures, turn off the EMIT 50571 and disconnect the battery charger/eliminator from its power source. Failure to observe this precaution could result in an electrical shock.
3. Allow a cool-down period to reduce the danger of burns from heated parts such as transistors and heat sinks.
4. This instrument incorporates a rechargeable 7.2 V battery pack. Do not substitute a non-rechargeable battery because risk of fire or explosion could result. Please contact EMIT or an authorized service organization for battery replacement information.

Please go to our website: DescoEMIT.com for a complete list of our sales and service representatives and distributors located in the United States and throughout the world.

Preface

This manual provides user information for the EMIT 50571 Charged Plate Analyzer and contains the following chapters and appendixes:

- **Introduction** contains a brief product description and describes an incoming confidence test for the unit.
- **Installation** contains initial setup information for the EMIT 50571.
- **Operation** contains a description of the product's features and a detailed explanation of proper operating procedures.
- **Specifications** states the requirements, behavior, and performance of the instrument in a concise format.
- **Maintenance** contains proper care and preventative maintenance guidelines for the instrument.
- **Appendix A: Accessories** describes other products that are useful with the EMIT 50571.
- **Appendix B: Warranty Statement** describes terms and conditions of the EMIT Warranty Statement.
- **Appendix C: Sales & Service** contains EMIT contact information. (*Please go to our website: DescoEMIT.com for a complete list of our sales and service representatives and distributors located in the United States and throughout the world.*)

Section I Introduction



Danger: EMIT high-voltage generating equipment, including EMIT amplifiers and supplies are not designed, rated, or qualified to be operated in an environment or atmosphere which contains combustible or explosive materials or gases which may be ignited by electrical discharges.

This manual provides instructions to install and operate the EMIT 50571 Charged Plate Analyzer. We recommend you take the time to read this manual to take full advantage of the features and benefits of the instrument.

General Information

The EMIT 50571 Charged Plate Analyzer is designed to provide quantitative and accurate measurements for a variety of air ionization tests in any location. The OUTPUT MONITOR connector on the rear panel is a buffered output providing a low-voltage replica of the voltage on the ion collecting plate.

The EMIT 50571 employs a revolutionary new charged-plate monitor design that utilizes an ultra-high-impedance high-voltage follower to monitor the ion collecting plate voltage. This technique provides very high accuracy and virtually infinite impedance loading of the plate, while allowing the ion collecting plate to be charged and monitored through the same small-diameter connection.

This technique also makes the measurement capacitance independent of the physical size and shape of the ion collecting plate. Therefore, the size and shape of an ion collecting plate, as well as the measurement capacitance, may be customer specified to match a particular ESD-sensitive device within a manufacturing process, or it may be made to conform to the ESD Association Standard ANSI/ESD-STM3.1.

Modes of Operation

The EMIT 50571 features three primary modes of operation: a negative (-) decay mode, a positive (+) decay mode, and a float mode. Decay mode START and STOP voltages are easy to program.

Use for Product Qualification and Compliance Verification testing of Ionizers per ANSI/ESD S20.20 testing per ANSI/ESD STM3.1 and ESD TR53. Use Decay mode to measure Discharge Times; the required limit is to be determined by the user. Use the Float Mode to determine the ionizer's offset voltage; the Offset Voltage required limit per ANSI/ESD S20.20 is ± 35 volts.

For DECAY mode operation, the ion collecting plate is pre-charged, either positively or negatively, to a level above the programmed START voltage. The time required to discharge the ion collecting plate from the programmed START voltage to the programmed STOP voltage is measured by the EMIT 50571. The discharge is due to 'incident ion flow' on the ion collecting plate.



Warning: Hazardous voltages may be present on ion plate during Decay mode operation.

For the FLOAT mode operation, the plate is initially discharged to zero and then allowed to float to the voltage level dictated by 'incident ion flow' on the ion collecting plate.

The simplicity of the design of the EMIT 50571 makes it very reliable and completely portable. The EMIT 50571 is powered by a rechargeable battery (supplied) that offers 8 hours of operation from a full charge. The unit can also be operated from a line supply using a battery eliminator/charger.



Caution: This instrument incorporates a rechargeable 7.2 V battery pack. Do not substitute a non-rechargeable battery because risk of fire or explosion could result. Please contact EMIT or an authorized service organization for battery replacement information.

Incoming Inspection

Visually inspect the instrument for physical damage such as dents, nicks, scratches, broken fittings, etc. External damage may indicate more serious damage has occurred within the instrument. In the event of damage, contact EMIT Customer Service. Attempts to operate a damaged instrument may cause permanent damage to the instrument.

Incoming Confidence Test

The EMIT 50571 undergoes extensive checks and adjustments at the factory, and no initial calibration should be required. However, you may wish to perform an incoming confidence test as part of the incoming inspection on the instrument. An incoming confidence test of this nature is intended to confirm that the instrument was not damaged in transit.

We recommend that you familiarize yourself with the information in Section II and Section III before performing this test.

Placing a charged object near the ion collecting plate while the instrument is in the DECAY mode and measuring the decay time of the object would constitute a reasonable incoming confidence test. A simple source for a charged object is an ordinary pocket comb or a hard plastic screw driver. A pocket comb drawn through the hair will usually produce a negative charge on the comb. A hard plastic handle of a screw driver brushed against a pant leg will usually produce a positive charge on the handle of the screw driver.



Warning: Do not turn on the EMIT 50571 until instructed to do so. To do so before the appropriate point in time could result in an electrical shock and/or damage to the instrument.

1. Ensure the power is OFF.
2. Connect the ion collecting plate to the ION COLLECTING PLATE connector on the rear panel.
3. Connect the GROUND jack to earth ground using the banana-alligator cable provided.
4. Place the MODE switch in the +DECAY position.
5. Turn on the power.
6. Momentarily press down on the TEST/RESET switch.
7. Move a negatively charged object (pocket comb) towards the ion collecting plate until the value indicated on the PLATE VOLTAGE display decreases below the programmed decay start voltage.

The decay timer will start when the plate voltage passes the programmed decay start voltage.

Note: The decay start voltage is factory programmed for 1000 V. (See 'Programming the START voltage' on page III-4 for information on changing the decay start voltage.)

Incoming Confidence Test (cont.)

8. Continue to move the negatively charged object towards the ion collecting plate until the value indicated on the PLATE VOLTAGE display passes through the programmed decay stop voltage.

Note: *The decay stop voltage is factory programmed for 100 V. (See 'Programming the STOP voltage' on page III-5 for information on changing the decay stop voltage.)*

At the programmed stop voltage the decay timer will stop and the decay time will be indicated on the DECAY TIME display.

This completes the incoming confidence test. Turn OFF the EMIT 50571.

Section II Installation

Mounting

The EMIT 50571 is designed to be operated as a portable bench top instrument. There are no special mounting requirements.

Battery Operation

Initially charge the EMIT 50571 for 3 hours before operating the instrument. The FULL CHARGE indicator will illuminate when the battery is fully charged.

The EMIT 50571 will operate for at least 8 hours with a full charge.

The LOW BATTERY indicator will illuminate when the battery is approximately 30 minutes from total discharge.



Caution: *This instrument incorporates a rechargeable 7.2 V battery pack. Do not substitute a non-rechargeable battery because risk of fire or explosion could result. Please contact EMIT or an authorized service organization for battery replacement information.*

Battery Charger/Eliminator Connection

The EMIT 50571 is designed to be battery operated or operated while connected to a line voltage source. A battery charger/eliminator is available for all nominal line voltages.

1. Ensure the power is OFF.
2. Plug the battery charger/eliminator to the CHARGER receptacle on the rear panel.
3. Plug the free end of the AC line cord into the power source.



Figure 2-1: Battery Charger/Eliminator connector polarity.

Initial Setup Connections

Before operating the EMIT 50571, the following connections should be made:

Ground Connection

The EMIT 50571 must be connected to a solid ground reference to ensure accurate and repeatable measurements. All voltage measurements will be made with respect to this ground reference point. The power to the unit should be OFF when connecting the ground on the rear panel of the unit to a ground reference.

Ion Collecting Plate Connection



Ensure that the power to the unit is OFF when connecting the plate cable to the ION COLLECTING PLATE receptacle on the rear panel.



Note: Hazardous voltages may exist in the plate receptacle if the power to the unit is ON. See warning below under OUTPUT MONITOR CONNECTION.

Output Monitor Connection



Warning: Exercise extreme caution while connecting a BNC connector cable to the OUTPUT MONITOR BNC receptacle. Do not confuse the OUTPUT MONITOR BNC cable connector for the ION PLATE BNC cable connector. Inserting the OUTPUT MONITOR connector into the ION PLATE connector could deliver a voltage of 1100 volts to the BNC shell.

The OUTPUT MONITOR connector on the rear panel is a buffered output providing a low-voltage replica of the voltage on the ion collecting plate.

The voltage at this output represents 1/200th the voltage on the ion collecting plate. Connect a monitoring device, such as an oscilloscope, to this connector to monitor the voltage on the ion collecting plate. The signal at this connector can also be used as a feedback signal in a closed-loop system.

Section III Operation

Front Panel Features

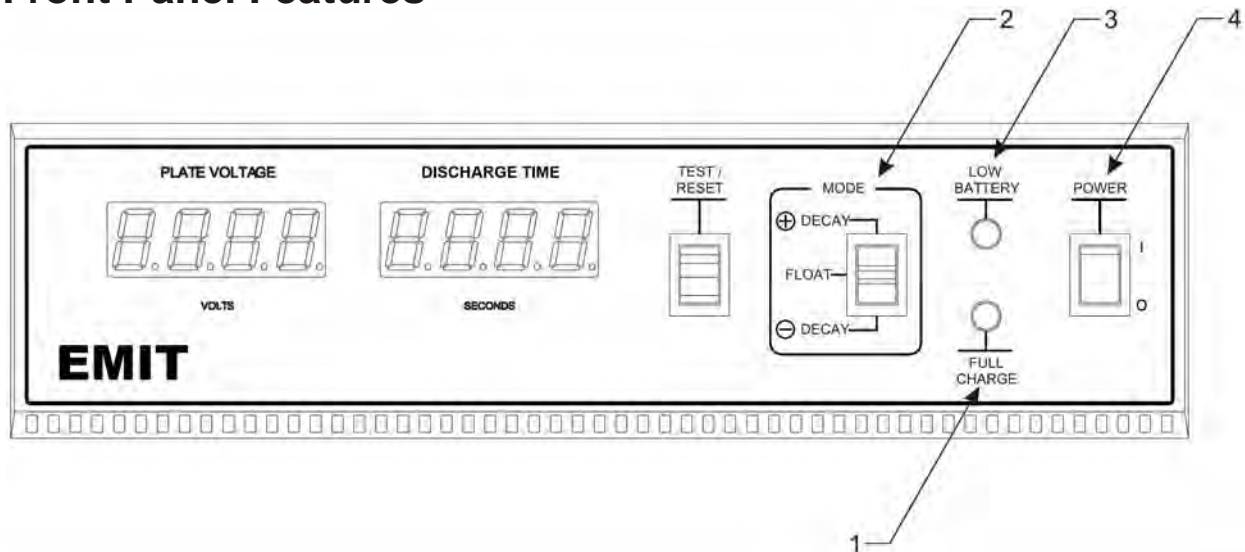

Figure 3-1: Front Panel Features

1. **FULL CHARGE Indicator:** This indicator will illuminate when the battery is fully charged. At least 8 hours of operation can be expected from a fully charged battery.
2. **MODE Switch:** This switch selects either the (+) DECAY, the (-) DECAY or the FLOAT mode of operation. This switch is also used in combination with the TEST/RESET switch to program the start and stop voltages.
3. **LOW BATTERY Indicator:** This indicator will illuminate when the battery is approximately 30 minutes from being fully discharged.
4. **POWER Switch:** This switch turns the power ON and OFF and may enable initial high-voltage to the plate.



Warning: The EMIT 50571 is battery operated and high-voltage may be present at the ion collecting plate or ion plate connector whether or not the battery charger/eliminator is connected to the rear panel when the POWER switch is ON.

Front Panel Features (cont.)

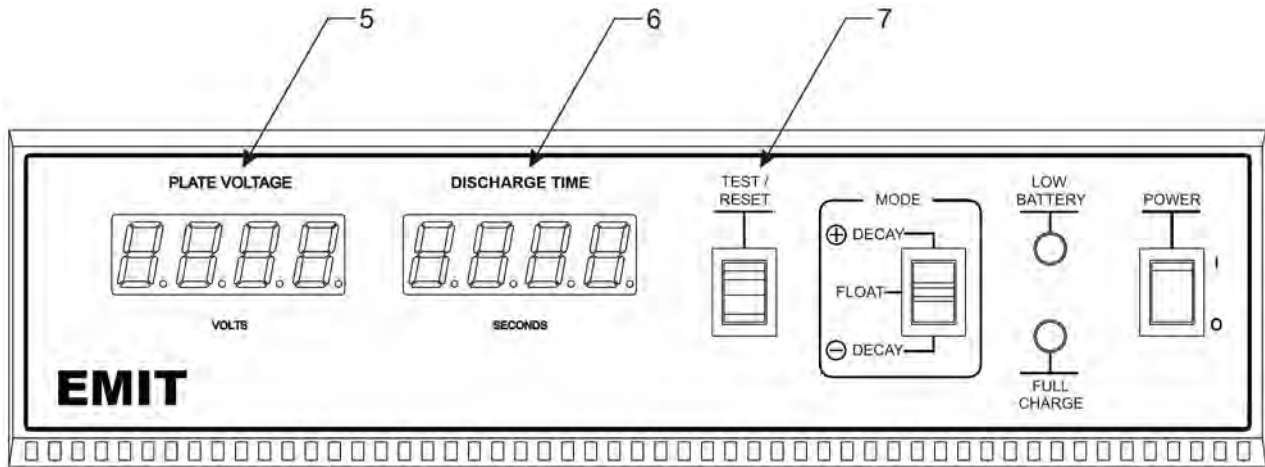

Figure 3-2: Front Panel Features (cont.)

5. **PLATE VOLTAGE Display:** This digital display indicates the plate voltage in volts.
6. **DECAY TIME Display:** This digital display indicates the time in seconds for the ion collecting plate to discharge from the programmed START voltage to the programmed STOP voltage.
7. **TEST/RESET Switch:** This switch sets the plate voltage to greater than the programmed START voltage when the instrument is in the (+) DECAY or (-) DECAY mode. This switch sets the plate voltage to 0 volts when the instrument is in the FLOAT mode.

This switch is also used in combination with the MODE switch to program the START and STOP voltages.

Rear Panel Features

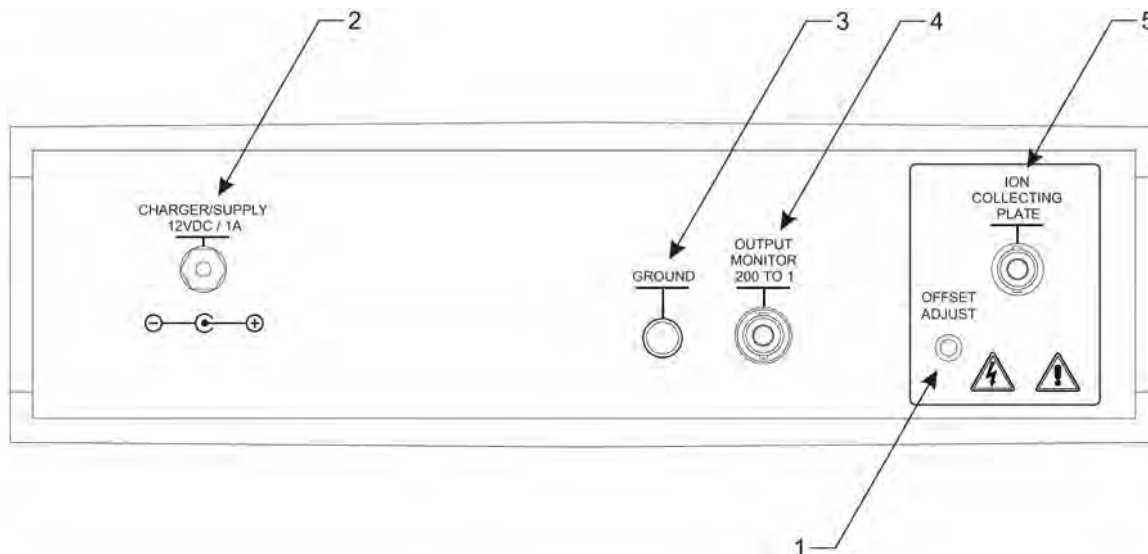

Figure 3-3: Rear Panel Features

1. **OFFSET ADJUST:** This adjustment minimizes plate voltage drift. The calibration is factory set and should not need adjustment.
2. **CHARGER/SUPPLY Receptacle:** This receptacle is for connection of the battery eliminator/charger.
3. **GROUND Jack:** This banana jack is for connection to a ground reference point.
4. **OUTPUT MONITOR Connector:** This BNC provides a buffered, low-voltage replica of the voltage on the ion collecting plate. The voltage at this output is 1/200th of the voltage on the ion collecting plate.



Warning: Exercise extreme caution while connecting a BNC connector cable to the OUTPUT MONITOR BNC receptacle. Do not confuse the OUTPUT MONITOR BNC cable connector for the ION PLATE BNC cable connector. Inserting the OUTPUT MONITOR connector into the ION PLATE connector could deliver a voltage of 1100 volts to the BNC shell.

5. **ION COLLECTING PLATE Receptacle:** This BNC receptacle is for connection of the ion collecting plate.



Warning: The EMIT 50571 is battery operated and high-voltage may be present at the ion collecting plate or ion plate connector whether or not the battery charger/eliminator is connected to the rear panel when the POWER switch is ON.

FLOAT Mode Operation

In the FLOAT mode, the EMIT 50571 monitors the voltage on the plate caused by air ion imbalance.

1. Place the ion collecting plate in the area to be monitored.
2. Place the MODE switch in the FLOAT mode.
3. Press down and release the TEST/RESET switch to apply 0 volts to the plate. Upon releasing the TEST/RESET switch, the plate will “float” to a voltage as dictated by air ion imbalances.

DECAY Mode Operation

In the positive (+) DECAY and negative (-) DECAY modes, the EMIT 50571 monitors the time taken for the ion collecting plate to decay from the programmed START voltage to the programmed STOP voltage.

1. Place the ion collecting plate in the area to be monitored.
2. Place the MODE switch in either the positive (+) DECAY or negative (-) DECAY mode:

In the positive (+) DECAY mode the ion collecting plate is charged to a positive voltage. In the negative (-) DECAY mode the ion collecting plate is charged to a negative voltage.

3. Press and release the TEST/RESET switch.

The ion collecting plate will charge to a value slightly greater than the programmed START voltage. The decay timer will start when the plate voltage reaches the programmed START voltage. The decay timer will stop when the plate voltage reaches the programmed STOP voltage.

Programming Operation

The EMIT 50571 can be operated in any one of three modes, the (+) DECAY mode, the (-) DECAY mode, and the FLOAT mode.

Note: When the instrument is first turned on, it will indicate the revision level of the program in the DECAY TIME display. The unit will also flash the (previously) programmed START voltage in the PLATE VOLTAGE display and the (previously) programmed STOP voltage in the DECAY TIME display. The START and STOP voltages are initially factory set to 1000 V and 100 V, respectively.

Programming the START voltage

1. Ensure the power is OFF.
2. Place the MODE switch to the FLOAT position.
3. Press and hold down the TEST/RESET switch. Keep the switch down when turning ON the POWER switch.
4. After the POWER switch is turned on, the letter 'S', representing START voltage, appears in the PLATE VOLTAGE display.
5. Release the TEST/RESET switch. The DECAY TIME display will indicate the present START voltage.
6. Place the MODE switch in the positive (+) DECAY position to increase the START voltage. The START voltage will automatically *increase* in 1 volt increments.

Place the MODE switch in the negative (-) DECAY position to decrease the START voltage. The START voltage will automatically *decrease* in 1 volt increments. Select the voltage value desired for testing. When the desired START voltage parameter is obtained, place the MODE switch in the FLOAT position.

Note: The START voltage cannot be set above 1000 V or below the programmed STOP voltage

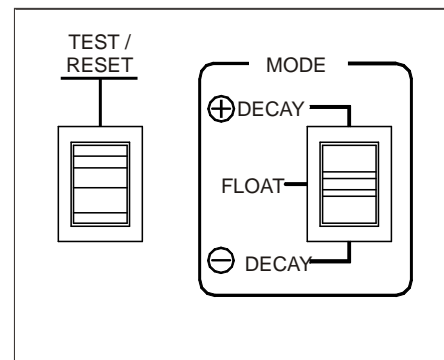

Programming Operation (cont.)

Programming the STOP voltage

1. After the START voltage has been programmed, press and hold down the TEST/RESET switch. The letter "E", representing "END" (STOP) voltage, appears in the PLATE VOLTAGE display.
2. Release the TEST/RESET switch. The DECAY TIME display will indicate the present STOP voltage.
3. Place the MODE switch in the positive (+) DECAY position to increase the STOP voltage. The STOP voltage will automatically *increase* in 1 volt increments.

Place the MODE switch in the negative (-) DECAY position to decrease the STOP voltage. The STOP voltage will automatically *decrease* in 1 volt increments. Select the voltage parameter desired for testing. When the desired START voltage is obtained, place the MODE switch in the FLOAT position

Note: *The STOP voltage cannot be set above the programmed START voltage or below 0 V.*

4. Press and hold down the TEST/RESET switch. The letter "P", representing 'PROGRAM', appears in the PLATE VOLTAGE display.

Release the TEST/RESET switch. The EMIT 50571 stores the new settings for START and STOP voltages and resets itself to begin testing for the newly chosen parameters.

The EMIT 50571 will display the 'revision level' of the command program and then will flash the new START voltage in the PLATE VOLTAGE display and the new STOP voltage in the DECAY TIME display. The unit will then go into the normal operating mode as set by the MODE switch.

Monitoring the Plate Voltage using the Output Monitor

The OUTPUT MONITOR receptacle provides a low-voltage replica of the plate voltage. The OUTPUT MONITOR voltage is 1/200th of the plate voltage. The OUTPUT MONITOR can be connected to an oscilloscope for visual representation of the ion tests.

For example, if the plate voltage is 500 V, the voltage at the OUTPUT MONITOR receptacle would be:

$$500 \text{ V} \times 1 \text{ V}/200 \text{ V} = 2.5 \text{ V}$$

Section IV EMIT 50571 Specifications

DANGER: This instrument is not rated for use in an explosive environment. DO NOT use it in an explosive environment or an explosion may result.

PERFORMANCE

Monitored Voltage Range	0 to ± 1100 V DC or peak AC.
Small Signal Bandwidth (-3 dB)	DC to 1 kHz (measured at 20 V p-p).
Large Signal Bandwidth	DC to 10 Hz (measured at 2000 V p-p).
Zero Stability (referred to plate voltage)	
Drift with Time (no incident ion flow)	Less than 6 V/minute.
Drift with Temperature	Less than 10 mV/ $^{\circ}$ C, noncumulative.
Decay Mode Thresholds	
Start Voltage	Programmable from 1 to ± 1000 V in 1 V increments.
Start Accuracy	Within ± 1 V of programmed start voltage.

Specifications

Specifications (cont.)

PERFORMANCE (cont.)

Decay Mode Thresholds (cont.)

Stop Voltage	Programmable from 0 to ± 999 V in 1 V increments.
Stop Accuracy	Within ± 1 V of programmed stop voltage.
Plate Self-Discharge (unpolarized)	Less than 12 V/minute.

FEATURES

Power On/Off	A two-position rocker switch.
Test/Reset Control	A momentary toggle switch used in conjunction with the Mode Select Switch to program the START and STOP voltages.
+Decay and -Decay Modes	Set the plate voltage to a value greater than the programmed start voltage and reset the decay timer to zero.
Float Mode	Sets the plate voltage to $0\text{ V} \pm 2\text{ V}$.
Voltage Monitor Output	A BNC providing a low voltage replica of the plate voltage.
Scale Factor	1/200th of the plate voltage.
DC Accuracy	Better than 0.1% of full scale.
Offset Voltage	Less than ± 10 mV.
Output Noise	Less than 10 mV rms (measured using the true rms feature of the Hewlett Packard Model 34401A digital multimeter).
Output Impedance	Less than 0.1 ohm.

Specifications (cont.)

FEATURES (cont.)

Plate Voltage Digital Panel Meter	3 ½ digit red LED display.
Range	0 to ±1100 V.
Resolution	1 volt.
Accuracy	Better than 0.1% of full scale, ±1 count.
Decay Time Digital Panel Meter	4-digit red LED display.
Range	0 to 9999 seconds.
Resolution	0.1 seconds, from 0 to 999.9 seconds; 1 second, from 1000 to 9999 seconds. (The display will indicate “- - -” when the decay time exceeds 9999 seconds.)
Ion Collector Plate	
Standard Option	Meets ESD Association Standard ANSI/ESD-STM3.1 requirements for:
Dimensions	15.3 cm x 15.3 cm square, (6 ² x 6 ² square).
Capacitance	20 pF ±2 pF.
Non-standard Option	
Dimensions	Specify when ordering.
Capacitance	Specify when ordering.
Mode Select	A three-position toggle switch that selects the +Decay, the -Decay, or the Float mode of operation. This switch is also used in combination with the Test/Reset Control switch to program the start and stop voltages.

Specifications

Specifications (cont.)

GENERAL

Power Requirements

Battery Eliminator/Charger

Optionally available for all nominal line voltages. Contract EMIT or an authorized service organization for more information. NOTE: If line impulses exceed 500 V when using the battery eliminator/charger, the unit may reset and require operator assistance



Specifications

Output Connector

2.1 mm DC power plug.

Output Voltage

12 to 14 V DC.

Output Current

1 A.

Battery Operation

Rechargeable battery supplied.

Operating Time

8 hours with full charge.

Recharge Time

3 hours to full charge.

Other

Low battery indicator.
Full charge indicator.

Operating Conditions

Temperature

5 °C to 35 °C.

Relative Humidity

To 80%, noncondensing.

Specifications (cont.)

MECHANICAL

Instrument Dimensions	83 mm H x 318 mm W x 280 mm D (3.25" H x 12.5" W x 11" D).
Instrument Weight	2 kg (4.4 lb).
Voltage Monitor Connector	BNC coaxial connector. (3 meter length, maximum.)
Ground Receptacle	Banana jack.
Battery Eliminator/ Charger Receptacle	2.1 mm DC power plug.
Cable from Instrument to Floating Plate	Coaxial type.
Diameter	4.95 mm (0.195") or 2.6 mm (0.102").
Length	3 m (10 ft), nominal.

Specifications

Specifications (cont.)

Certification and Compliance

Certification

EMIT certifies that each 50571 is tested and calibrated to specifications using measurement equipment traceable to the National Institute of Standards and Technology or traceable to consensus standards. A Certificate of Calibration accompanies each instrument when it is shipped from the factory.

Low Voltage Safety Compliance

EN 61010-1

Overvoltage Category

CAT I: Peripheral level outputs (less than 60 volts).

Pollution Category

Degree 1: Operate in environments where no pollution or only dry, nonconductive pollution occurs.

Section V Maintenance

Safety Precautions for the EMIT 50571

Please observe the following safety precautions when checking connections or providing maintenance procedures on the EMIT 50571:

1. Refer all maintenance procedures to qualified personnel.
2. Prior to performing maintenance procedures, turn off the EMIT 50571 and disconnect the battery charger/eliminator from its power source. Failure to observe this precaution could result in an electrical shock.
3. Allow a cool-down period to reduce the danger of burns from heated parts such as transistors and heat sinks.
4. This instrument incorporates a rechargeable 7.2 V battery pack which is not user serviceable. Do not substitute a non-rechargeable battery because risk of fire or explosion could result. Please contact EMIT or an authorized service organization for battery replacement information.

Please go to our website: DescoEMIT.com for a complete list of our sales and service representatives and distributors located in the United States and throughout the world.

Battery Pack Maintenance

The EMIT 50571 is equipped with a rechargeable battery pack. Periodic cycling (complete charge and discharge) of the battery pack is required in order to maximize the life and capacity of the battery pack. EMIT recommends cycling the battery pack at least once a month. Cycling of the battery pack can be accomplished by following the procedure below.

- 1) Plug the battery eliminator/charger into the EMIT 50571.
- 2) Charge the battery pack until the "Full Charge" indicator on the EMIT 50571 is illuminated.
- 3) Remove the charger from the EMIT 50571.
- 4) Turn the power to the EMIT 50571 on.

Battery Pack Maintenance (cont.)

- 5) Leave the EMIT 50571 "ON" for more than 12 hrs.
- 6) Plug the battery eliminator/charger into the EMIT 50571.
- 7) Charge the battery pack until the "Full Charge" indicator on the EMIT 50571 is illuminated.
- 8) Cycling is completed.

Note: An apparent loss of capacity for the battery pack ("Memory Effect") might be noticed if the battery pack is left on *charge*, for a long period of time. This effect can be reversed by cycling the battery pack 1-3 times.

Preventative Maintenance

Preventative maintenance consists of inspecting and cleaning the instrument. Preventative maintenance performed on a regular basis may prevent instrument failure and improve reliability.

INSPECTION: Visually inspect the instrument for loose or damaged controls and connectors or other undesirable conditions.

CLEANING: Clean the EMIT 50571 as operating conditions require.

Clean the exterior of the instrument with a damp cloth. The use of solvents may damage the finish or plastic components. A small brush is effective in removing dirt from the front and rear panel controls and connectors.

Customer Service Assistance

In the event that you require assistance on a maintenance item, direct your request for assistance to EMIT Customer Service. Please go to our website: DescoEMIT.com for a complete list of our sales and service representatives and distributors located in the United States and throughout the world.

Telephone assistance is usually effective for obtaining additional maintenance information which is beyond the scope of this manual. Troubleshooting advice which is given over the telephone may be useful for solving the simpler malfunctions or confirming that the system should be returned to the factory.

Service Information

Note: The warranty is voided if the instrument is serviced within the warranty period by anyone other than EMIT.

In the event of a malfunction, and the instrument must be returned for repair:

1. Notify EMIT Customer Service, giving full details about the difficulty, including the model number and serial number of the instrument. Customer Service will issue a return authorization number.
2. Forward the instrument (prepaid), with the return authorization number prominently displayed on the shipping container and the packing list, to EMIT

Please go to our website: DescoEMIT.com for a complete list of our sales and service representatives and distributors located in the United States and throughout the world.

Appendix A Warranty Statement

LIMITED WARRANTY & F.O.B. Point SATISFACTION GUARANTEED

WE GUARANTEE YOU WILL BE SATISFIED WITH OUR PRODUCTS. We have always had a policy of replacement or refund if you are not satisfied. EMIT wants you to be satisfied with each product we produce. We make every effort to see to it that our products are of the highest quality and meet all appropriate recognized industry standards. Since we cannot guarantee that all products are applicable to all situations and that the data we provide from many sources is reliable and accurate for all situations, our lawyers want you to know that ...

All statements, technical data, and recommendations contained herein are based upon tests we believe to be reliable. However, the accuracy or completeness thereof is not guaranteed. The proper and correct application of products and data is the responsibility of the user. The following is made in lieu of all warranties, expressed or implied:

EMIT's only obligation shall be to replace such quantity of the product proved to be defective. EMIT shall not be liable for any injury, loss, or damage, direct or consequential, arising out of the use of or the inability to use the product. Before using, users shall determine the suitability of the product for their intended use, and users assume all risk and liability whatsoever in connection therewith.

No statement or recommendation not contained herein shall have any force or effect unless embodied in a written agreement signed by authorized officers of Desco Industries, Inc.

Limited Warranty

Effective 2013-11-01: EMIT products are offered with a 1 year warranty.

EMIT expressly warrants that for a period of one (1) year from the date of purchase, EMIT products will be free of defects in material (parts) and workmanship (labor). Within the warranty period, a credit for purchase of replacement EMIT products, or, at EMIT's option, the product will be repaired or replaced free of charge. Call our Customer Service Department at (909) 664-9980 (Chino, CA) for a Return Material Authorization (RMA) and proper shipping instructions and address. Please include a copy of your original packing slip, invoice, or other proof of date of purchase. Any unit under warranty should be shipped prepaid to the EMIT factory. Warranty replacements will take approximately two weeks.

Warranty Exclusions

THE FOREGOING EXPRESS WARRANTY IS MADE IN LIEU OF ALL OTHER PRODUCT WARRANTIES, EXPRESSED AND IMPLIED, INCLUDING MERCHANTABILITY AND FITNESS FOR A PARTICULAR PURPOSE WHICH ARE SPECIFICALLY DISCLAIMED. The express warranty will not apply to defects or damage due to accidents, neglect, misuse, alterations, operator error, or failure to properly maintain, clean or repair products.

Limit of Liability

Electronic ionizers use high voltage corona discharge and should not be used in or near flammable or explosive environments. In no event will EMIT or any seller be responsible or liable for any injury, loss or damage, direct or consequential, arising out of the use of or the inability to use the product. Before using, users shall determine the suitability of the product for their intended use, and users assume all risk and liability whatsoever in connection therewith.

Appendix A Warranty Statement

F.O.B. Point

Unless embodied in a written agreement signed by authorized officers of Desco Industries, Inc., the F.O.B. point for all products purchased from EMIT will be the F.O.B. factory.

OUT OF WARRANTY REPAIRS

Field repair or unauthorized tampering of EMIT brand products is not recommended and will nullify any and all warranties provided by DII. All EMIT items to be repaired must be returned to the DII factory in Chino, California. EMIT will quote repair cost upon receipt and inspection of product. Repaired product will include a 30 day warranty specific to repair work performed and parts used. A Return Merchandise Authorization number (RMA#) must be obtained from EMIT for out of warranty repairs. A copy of the RMA must accompany the shipment. The RMA number must appear on the outside of returned cartons, and EMIT has the right to refuse all return shipments which do not bear the RMA number or which are shipped freight collect. Customer is responsible for all freight and transportation charges.

EMIT expressly warrants that for a period of 30 days from the date of repair or calibration, EMIT repaired or calibrated products will be free of defects in material (parts) and workmanship (labor). Within this limited warranty period, a unit will be tested, repaired or replaced at EMIT's option, free of charge. E-mail our Customer Service Department at Service@DescoEMIT.com, for a Return Material Authorization (RMA) and proper shipping instructions and address. Please include a copy of your original packing slip, invoice, or other proof of date of repair or calibration. Any unit should be shipped prepaid to the EMIT factory.

Appendix B Sales & Service

Please go to our website: DescoEMIT.com for a complete list of our sales and service representatives and distributors located in the United States and throughout the world.

EMIT ASIA Authorize distributor / Agent :

Singapore (Head Office)

Pro-Pack Materials Pte Ltd

No 9, Bukit Batok St 22, #01-01,

Singapore 659585

Tel : +65-6354-1511

Fax : +65-6354-1711

Email : sales@pro-pack.com.sg

Indonesia - PT Pro-Pack Industries

Batam

JL Letjen Soeprapto

Cammo Industrial Park

Block A4 No.2 Batam Center, Indonesia

Tel : +62-778-463-046

Fax : +62-778-463-048

Thailand - Bold-Pack Materials (Thailand) Co. Ltd.

Bangkok

47/360 Kaitak Building 10th Floor, Cheangwattana Road,
T.BanMai, A.Pakkred Nonthaburi 11120 Thailand

Tel : +66-2-980-7118 / 119

Fax : +66-2-980-7117

Philippines - Pro-Pack Materials (Philippines) Inc.

Manila

Annex B Commerce Avenue

Warehouse Corporate Park

Brgy.Malilit, City of Sta.Rosa,

Laguna 4026, Philippines.

Tel : +63-49-5342-803

Fax : +63-49-832-1392

Malaysia - Bold Pack Industries Sdn Bhd

Penang

102-K, Lengkok Kampung Jawa Dua, Kawasan MIEL,
11900 Bayan Lepas,
Penang , Malaysia .
Tel : +60-4-642-9087
Fax : +60-4-642-9309

Ipoh

97,Medan Stesen 19,Station 18,
31650 Ipoh, Perak, Malaysia.
Tel : +60-5-322-9087
Fax : +60-5-322-9086

Kuala Lumpur

No 27 Jalan USJ 1/13 Taman Perindustrian USJ 1
47600 Subang Jaya
Selangor Darul Ehsan, Malaysia
Tel : +60-3-8025-9087
Fax : +60-3-8024-9309

Malacca

No 37,Ground Floor, Jalan SP4,
Taman Semabok Perdana,
75050 Melaka. Malaysia.
Tel : +60-6-283-2063
Fax : +60-6-283-0931

Johore Bahru

No, 17, Jalan Impian Emas 2, Taman Impian Emas,
81300 Johor Bahru,
Johor Malaysia
Tel : +60-7-554-6070
Fax : +60-7-557-1295

India - Pro-Pack Materials India Pvt Ltd

Bangalore

No.855, 1st Floor, 6th Main, 3rd Cross, KSRTC Layout,
2nd Phase, JP Nagar,
Bangalore-560078
Tel : +91-80-6531-5488
Fax : +91-80-2658-3695
Website : www.pro-pack.co.in

Chennai - Corporate Office

No.65 Anusha Street
VGN Shanthi Nagar, Ambuttur
Chennai, Tamil Nadu, India 600053
Supply Chain Tel No. : +91-44-6458-0946
Accounts Tel No : +91-44-6458-0947
Sales Tel No: +91-44-6458-0948
Fax : +91-44-2625-7715

Chennai - Supply Chain Solutions

Old No.55 , New No 66.
EB Road 3rd Street, SIDCO Ambuttur Industrial Estate (North)
Chennai , Tamil Nadu, India 600098

Pune

GAT- No.516, Wagholi(Katkewadi),
Near Shell Petrol Pump, Pune-Nagar Highway,
Pune 412207
Tel : +91-82-3746-7974

